

# ATS-710-M THERMOSTREAM®

DATASHEET AND SPECIFICATIONS

**-80° to +225°C**



Advanced Temperature Source for fast and precise thermal conditioning of components, parts, hybrids, modules, subassemblies, and printed circuit boards. Capable of ultra-low temperatures **without** the use of Liquid Nitrogen (LN<sub>2</sub>) or Liquid Carbon Dioxide (LCO<sub>2</sub>).

## PERFORMANCE:

### Temperature Range\*

-75 to +225°C (50Hz)

-80 to +225°C (60Hz)

No LN<sub>2</sub> or LCO<sub>2</sub> Required

### Transition Rate\*

-55 to +125°C, approx. 10 seconds or less

125 to -55°C, approx. 10 seconds or less

### System Airflow Output\*

4 to 18scfm (1.9 to 8.5 l/s) Continuous

\* under nominal operating conditions  
ultimate low temperatures (±1°) achieved at 12scfm

## TEMPERATURE CONTROL:

### Temperature Display & Resolution

+/- 0.1°C

### Temperature Accuracy

1.0°C (when calibrated against NIST standard)

### DUT Temperature Control

proprietary control algorithm enables DUT temperature to be directly controlled

### DUT Sensor Ports

internal diode, thermocouples (T & K),  
RTD (100 Ohm platinum)

## FEATURES:

### ► Frost Free Feature

dry air purge for tester interface, prevents condensation: 0.5 to 3scfm (0.25 to 1.5 l/s)

### ► ECO Friendly Features

#### Automatic Power Reduction

reduces power usage during idle periods

#### Heat Only Mode

reduces power usage when cold temperatures are not used

### ► Heated Defrost Feature

quickly removes moisture buildup from internal chiller

### ► Fully Adjustable Thermal Head

### ► Windows® OS

### ► Local & Remote Operations

### ► LabView™ & LabWindows® drivers

### ► On-Screen Help

### ► Ethernet, IEEE-488, RS232 ports

### ► USB, keyboard, mouse, & printer ports

### ► customizable and savable test setups

### ► Program & Datalog Storage (via ethernet or USB)

### ► User Defined Temperature Limits

## APPLICATION OPTIONS:

### ► Thermal Cap or FlexExtender Hose

4.5 or 5.5 inch ID Thermal Cap or optional FlexExtender Hose for connection to external Thermal Chambers or enclosures

### ► MobileTemp™ Thermal Chambers

Temperature Chambers designed specifically for uses with ATS THERMOSTREAM® Systems. See Additional Datasheets for details.

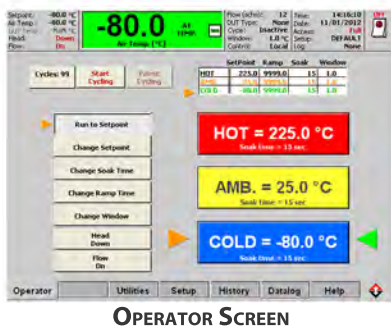

OPERATOR SCREEN

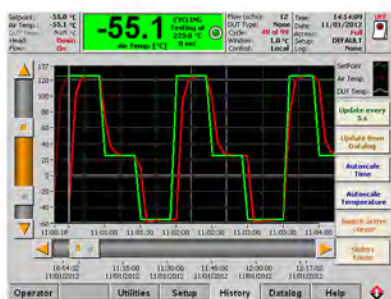

DATALOG SCREEN



System Dimensions - Standard

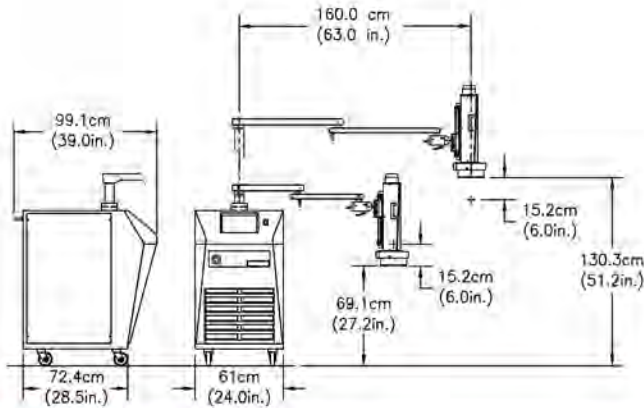

System Dimensions - Extended Height

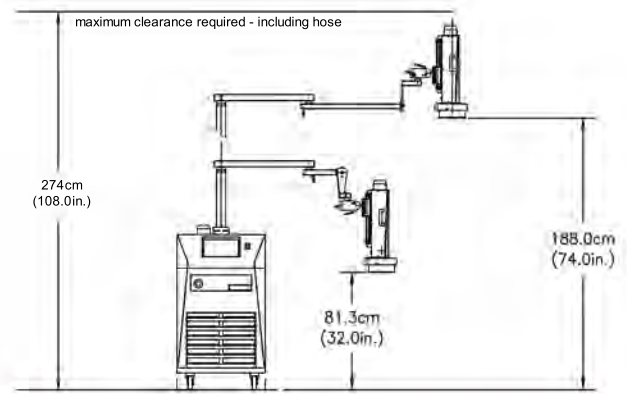

## Weights and Dimensions

<b>Base<sup>1</sup></b>	Width: 61.0 cm (24 in.), Depth: 72.4 cm (28.5 in.) Height: 108 cm (42.5 in.)
<b>System Weight</b>	Not packed: 236 kg (520 lbs.) Packed: 365 kg (805 lbs.)
<b>Mobility</b>	Four static dissipative, swivel caster wheels
<b>Maximum Reach</b>	160.0cm (63 in.)
<b>Maximum Operating Height</b>	130.3 cm (51.2 in.) - extended height option: 188.0 (74.0 in.)
<b>Minimum Operating Height</b>	69.1 cm (27.2 in.) - extended height option: 81.3 (32.0 in.)
<b>Noise Level</b>	<65dBA

<sup>1</sup> an additional 20.3cm (8 in.) clearance is required for supply connections and cabinet ventilation

## Service and Safety

<b>Refrigerants</b>	HCFC and CFC-free, non-toxic, non-flammable
<b>Serviceability</b>	Auto-diagnostics and field replaceable modules
<b>Over Temperature Protection</b>	+230°C (factory set): Operator can set high and low air temperature limits

## Facility Requirements

<b>Power<sup>2</sup></b>	200 - 250 VAC (230V nominal), 50/60Hz 30 amp, 1phase
<b>Compressed Air<sup>3</sup></b>	
<b>Clean, Dry Air (CDA)</b>	Filtered to 5 micron particulate contamination. Oil Content: <0.1 ppm, by weight, filtered to 0.01 micron oil contaminant. Dewpoint: <10°C @ 6.2 BAR (90PSI)
<b>Air Supply Pressure</b>	6.2 to 7.6 BAR (90 to 110 PSIG)
<b>Total Air Flow Rate Required</b>	7.1 to 14.2 l/s (15-30 scfm) 11.8 l/s (25 scfm) nominal
<b>Air Supply Temperature</b>	+20° to +25°C; +22°C nominal
<b>Operating Environment<sup>3</sup></b>	
<b>Operating Temperature</b>	+20° to +28°C; +23°C nominal
<b>Humidity</b>	0 to 60%; 45% nominal



**inTEST Thermal Solutions**  
41 Hampden Road  
Mansfield, MA 02048  
TEL: 1.781.688.2300  
www.inTESTthermal.com

ISO 9001 Certified



<sup>2</sup> System is configured for operation within voltages listed above using an internal transformer. Please specify power configuration with order

<sup>3</sup> Under operating conditions which are greater or less than nominal, performance may be less than specification provided